

DATA SHEET

QSFP10-LR4-C-GEN

40Gb/s QSFP+ LR4 Optical Transceiver

QSFP10-LR4-C-GEN Overview

QSFP10-LR4-C-GEN QSFP+ LR4 optical transceivers are based on Ethernet IEEE P802.3ba standard and SFF 8436 standard. The QSFP+ transceiver converts 4 inputs channels of 10Gb/s electrical data to 4 CWDM optical signals, and multiplexes them into a single channel for 40Gb/s optical transmission. Reversely, on the receiver side, the module optically de-multiplexes a 40Gb/s input into 4 CWDM channels signals, and converts them to 4 channel output electrical data. The central wavelengths of the 4 CWDM channels are 1271, 1291, 1311 and 1331 nm as members of the CWDM wavelength grid defined in ITU-T G694.2.

Product Features

- Uncooled 4x10Gb/s CWDM transmitter
- Up to 11.2Gbps data rate per wavelength
- QSFP+ MSA compliant
- Duplex LC connector
- Built-in digital diagnostic functions
- Up to 10km on SMF
- Maximum 3.5W operation power
- RoHS Compliant
- Operating temperature range: 0°C to 70°C

Applications

- 40G Ethernet
- Infiniband interconnects

Ordering Information

Part Number	Description	Color on Clasp
QSFP10-LR4-C-GEN	40G QSFP+ LR4 LC Connectors, Up to 10km on SMF, with DOM function	Blue
For More Information: SONGXIN TAIPEI TECH SOLUTIONS CO., LTD. Web: www.songxin.com.tw Email: oversea@songxin.com.tw		

General Specifications

Parameter	Symbol	Min	Typ	Max	Unit	Remarks
Bit Error Rate	BER			10^{-12}		
Operating Temperature	T _C	0		70	°C	1
Storage Temperature	T _{STO}	-40		85	°C	2
Input Voltage	V _{CC}	3.14	3.3	3.46	V	
Maximum Voltage	V _{MAX}	-0.5		3.6	V	3

Notes:

1. Case temperature
2. Ambient temperature
3. For electrical power interface

Link Distances

Data Rate	Fiber Type	Distance Range (km)
40 Gb/s	9/125um SMF	10

Optical – Characteristics – Transmitter

Parameter	Symbol	Min	Typ	Max	Unit	Remarks
Total Output Optical Power	P_T			8.3	dBm	1
Average Launch Power (Each Lane)	P_{TX}	-7		2.3	dBm	
Optical Center Wavelength(L0 Lane)	λ_c	1264.5	1271	1277.5	nm	
Optical Center Wavelength(L1 Lane)	λ_c	1284.5	1291	1297.5	nm	
Optical Center Wavelength(L2 Lane)	λ_c	1304.5	1311	1317.5	nm	
Optical Center Wavelength(L3 Lane)	λ_c	1324.5	1331	1337.5	nm	
Optical Modulation Amplitude	OMA	-4		3.5	dB	
Extinction Ratio	ER	3.5			dB	
Spectral Width (-20dB)	$\Delta\lambda$			1	nm	
Side Mode Suppression Ratio	SMSR	30			dB	
Relative Intensity Noise	RIN			-128	dB/Hz	
Transmitter Dispersion Penalty	TDP			2.3	dB	
Optical Return Loss Tolerance	TOL			20	dB	
Transmitter Eye Mask						2
Launch Power of OFF Transmitter, per lane	P_{OUT_OFF}			-30	dBm	1

Notes:

1. Average
2. Compliant with IEEE 802.3ba

Optical – Characteristics – Receiver

Parameter	Symbol	Min	Typ	Max	Unit	Remarks
Optical Center Wavelength (L0 Lane)	λ_c	1264.5	1271	1277.5	nm	
Optical Center Wavelength (L1 Lane)	λ_c	1284.5	1291	1297.5	nm	
Optical Center Wavelength (L2 Lane)	λ_c	1304.5	1311	1317.5	nm	
Optical Center Wavelength (L3 Lane)	λ_c	1324.5	1331	1337.5	nm	
Optical Input Power (each lane)	P_{RX}	-13.7		2.3	dBm	1
Damage Threshold (each lane)	P	3.3			dBm	
Receiver Sensitivity (OMA)(each lane)	R_{X_SEN1}			-11.5	dBm	
Receiver Reflectance	TR_{RX}			-26	dB	
LOS Assert	LOS_A	-28			dBm	
LOS De-Assert	LOS_D			-15	dBm	
LOS Hysteresis	LOS_H	0.5		6	dB	

Notes:

1. Average, Informative

Electrical – Characteristics – Transmitter

Parameter	Symbol	Min	Typ	Max	Unit	Remarks
Input differential impedance	R_{IN}		100		Ω	
Differential data input swing	V_{IN_PP}	120		1200	mV	
Transmit Disable Voltage	V_D	$V_{CC}-1.3$		V_{CC}	V	
Transmit Enable Voltage	V_{EN}	V_{EE}		$V_{EE}+0.8$	V	

Electrical – Characteristics – Receiver

Parameter	Symbol	Min	Typ	Max	Unit	Remarks
Differential data output swing	V_{OUT_PP}	400	550	800	mV	
Data output rise/fall time (20%-80%)	t_r/t_f	28			ps	
LOS Fault	V_{LOS_A}	$V_{CC}-1.3$		V_{CC_HOST}	V	
LOS Normal	V_{LOS_D}	V_{EE}		$V_{EE}+0.5$	V	

Block-Diagram-of-Transceiver

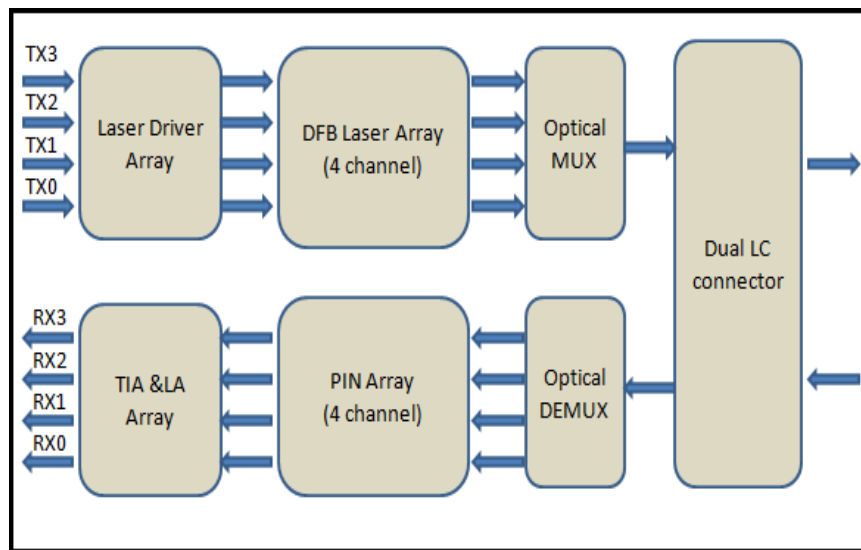

Functions Description

This product converts the 4-channel 10Gb/s electrical input data into CWDM optical signals (light), by a driven 4-wavelength Distributed Feedback Laser (DFB) array. The light is combined by the MUX parts as a 40Gb/s data, propagating out of the transmitter module from the SMF. The receiver module accepts the 40Gb/s CWDM optical signals input, and de-multiplexes it into 4 individual 10Gb/s channels with different wavelength. Each wavelength light is collected by a discrete photo diode, and then outputted as electric data after amplified by a TIA.

Dimensions

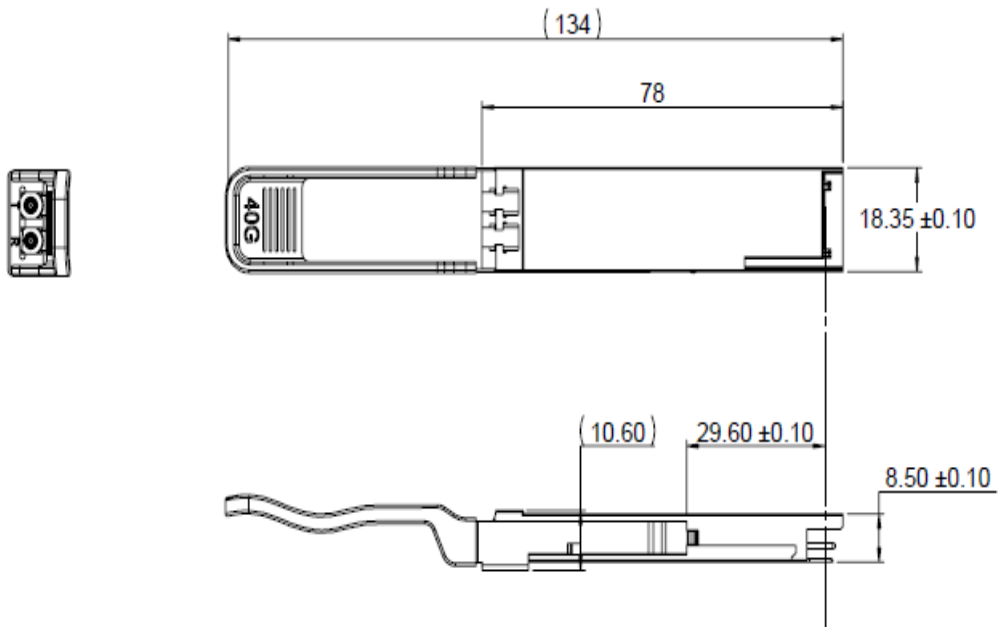

ALL DIMENSIONS ARE ± 0.2 mm UNLESS OTHERWISE SPECIFIED
UNIT: mm

Electrical Pad Layout

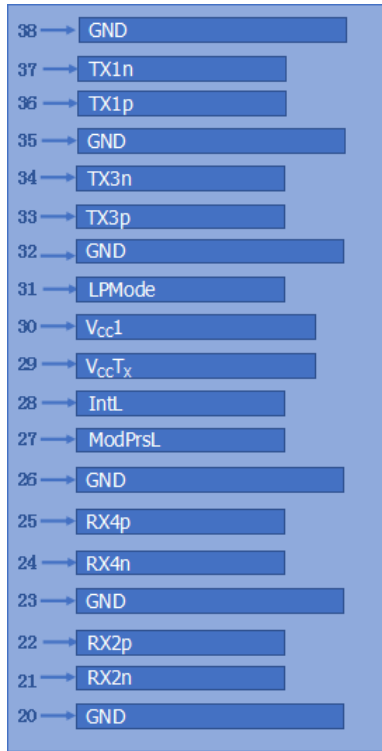

Top of Board

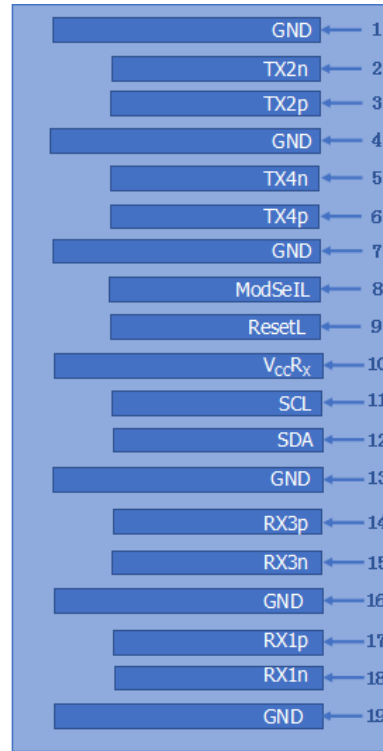

Bottom of Board

Pin Assignment

PIN #	Symbol	Description	Remarks
1	GND	Ground	5
2	Tx2n	Transmitter Inverted Data Input, LAN2	
3	Tx2p	Transmitter Non-Inverted Data Input, LAN2	
4	GND	Ground	5
5	Tx4n	Transmitter Inverted Data Input, LAN4	
6	Tx4p	Transmitter Non-Inverted Data Input, LAN4	
7	GND	Ground	5
8	ModSelL	Module select pin, the module responds to two-wire serial communication when low level	1
9	ResetL	Module Reset	2
10	V _{cc} R _X	+3.3V Power Supply Receiver	
11	SCL	2-wire serial interface clock	
12	SDA	2-wire serial interface data	
13	GND	Ground	5
14	Rx3p	Receiver Non-Inverted Data Output, LAN3	
15	Rx3n	Receiver Inverted Data Output, LAN3	
16	GND	Ground	5
17	Rx1p	Receiver Non-Inverted Data Output, LAN1	
18	Rx1n	Receiver Inverted Data Output, LAN1	
19	GND	Ground	5
20	GND	Ground	5
21	Rx2n	Receiver Inverted Data Output, LAN2	
22	Rx2p	Receiver Non-Inverted Data Output, LAN2	
23	GND	Ground	5
24	Rx4n	Receiver Inverted Data Output, LAN4	
25	Rx4p	Receiver Non-Inverted Data Output, LAN4	
26	GND	Ground	5
27	ModPrsL	The module is inserted into the indicate pin and grounded in the module.	3
28	IntL	Interrupt	4
29	V _{cc} T _X	+3.3V Power Supply transmitter	
30	V _{cc} 1	+3.3V Power Supply	
31	LPMODE	Low Power Mode	5
32	GND	Ground	5

33	Tx3p	Transmitter Non-Inverted Data Input, LAN3	
34	Tx3n	Transmitter Inverted Data Input, LAN3	
35	GND	Ground	5
36	Tx1p	Transmitter Non-Inverted Data Input, LAN1	
37	Tx1n	Transmitter Inverted Data Input, LAN1	
38	GND	Ground	5

Notes:

1. ModSelL is the input pin. The module responds to 2-wire serial communication commands when it is held low by the host. ModSelL allows multiple QSFP modules to be used on a single 2-wire interface bus. If ModSelL is High, the module will not respond to any 2-wire interface communication from the host. ModSelL has internal pull-up resistors in the module
2. The module restart pin, when the low level on the ResetL pin lasts longer than the minimum pulse length, resets the module and restores all user modules to their default state. When performing reset device, the host should ignore all status bits. Until the module reset interrupt is completed, please note that during hot plugging, the module will issue this information to complete the reset interrupt without resetting
3. This pin is active high, indicating that the module is running under a low power module.
4. IntL is the output pin, which is the open collector output and must be pulled up to Vcc on the motherboard. When it is low, it indicates that the module may malfunction. The host uses a 2-wire serial interface to identify the interrupt source
5. Circuit ground is internally isolated from chassis ground.

References

1. IEEE standard 802.3ba. IEEE Standard Department, 2010.
2. [QSFP+ 10Gbps 4X PLUGGABLE TRANSCEIVER –SFF-8436.](#)