

DATA SHEET

XFP-10G-SR-C-GEN

10 Gigabit 850nm MultiMode XFP Optical Transceiver

XFP-10G-SR-C-GEN Overview

XFP-10G-SR-C-GEN 10Gb/s XFP optical transceivers are designed for the IEEE 802.3ae 10GBASE-SR, 10GBASE-SW and 10GFC 1200-Mx-SN-I interconnects. The product implements digital diagnostics functions via a 2-wire serial interface, compliant with XFP Multi-Source Agreement (MSA) Specification.

Product Features

- Up to 11.3Gb/s bit rates.
- Compliant with IEEE 802.3ae, 10GBASE-SR/SW, 10GFC application.
- Compliant with XFP MSA.
- Uncooled 850nm VCSEL laser.
- Standard bail mechanism for consistent installation and removal
- Built-in digital diagnostic functions.
- Hot Pluggable XFP footprint.
- Duplex LC Connectors.
- Low power consumption (Module work consumption <1.5W)
- Up to 300m on MMF
- Power Supply: 3.3V
- RoHS Compliant
- Operating temperature range: 0°C to 70°C

Applications

- 10GBASE-SR 10G Ethernet
- 10GBASE-SW 10G Ethernet
- 1200-Mx-SN-I 10G Fiber Channel

Ordering Information

Part Number	Description	Color on Clasp
XFP-10G-SR-C-GEN	10 Gigabit XFP Transceiver, LC Connectors, 850nm, Multimode Fiber 300m	Cream color
For More Information: SONGXIN TAIPEI TECH SOLUTIONS CO., LTD. Web: www.songxin.com.tw Email: oversea@songxin.com.tw		

Absolute Maximum Ratings

Parameter	Symbol	Min	Typ	Max	Unit	Remarks
Storage Ambient Temperature	T _s	-40		85	°C	
Supply Voltage 3.3V	V _{CC}	-0.5		4	V	

General Specifications

Parameter	Symbol	Min	Typ	Max	Unit	Remarks
Data Rate	DR	9.95		11.3	Gb/s	1
Bit Error Rate	BER			10 ⁻¹²		
Total Power Consumption	P			1.5	W	
Supply Voltage	V _{CC3}	3.14		3.46	V	2
Supply Current	I _{CC3}			350	mA	
Case Operating Temperature	T _C	0		70	°C	3

Notes:

- 10GBASE-SR/SW 1200-Mx-SN-I
- Operating Environment
- Case temperature

Link Distances

Data Rate	Fiber Type	Modal Bandwidth @850nm (MHz-km)	Distance Range (m)
9.95 –11.3 Gb/s	62.5/125um MMF	160	2-26
	62.5/125um MMF	200	2-33
	50/125um MMF	400	2-66
	50/125um MMF	500	2-82
	50/125um MMF	2000	2-300

Optical – Characteristics – Transmitter

$V_{CC3}=3.14V$ to $3.46V$, $T_C=0^{\circ}C$ to $70^{\circ}C$

Parameter	Symbol	Min	Typ	Max	Unit	Remarks
Optical Center Wavelength	λ_c	840	850	860	nm	
Output Optical Power	P_{TX}	-7		-1	dBm	1
Extinction Ratio	ER	3	5.5		dB	
Spectral Width (RMS)	$\Delta\lambda$			0.45	dB	
Relative Intensity Noise	RIN			-128	dB/Hz	
Transmitter Dispersion Penalty	TDP			3.9	dB	
Launch Power of OFF Transmitter	P_{OUT_OFF}			-30	dBm	1
Transmitter Jitter	According to IEEE 802.3ae requirement					

Notes:

1. Average

Optical – Characteristics – Receiver

$V_{CC3}=3.14V$ to $3.46V$, $T_C=0^{\circ}C$ to $70^{\circ}C$

Parameter	Symbol	Min	Typ	Max	Unit	Remarks
Center Wavelength Range	λ_C	840		860	nm	
Receiver Overload	P_{OL}	0.5			dBm	
Receiver Sensitivity @10.3Gb/s	R_{X_SEN}			-10	dBm	1
Receiver Reflectance	TR_{RX}			-12	dB	
LOS Assert	LOS_A	-30			dBm	
LOS De-Assert	LOS_D			-14	dBm	
LOS Hysteresis	LOS_H	0.5			dB	

Notes:

1. Measured with worst ER: $BER < 10^{-12}; 2^{31}-1$ PRBS

Electrical – Characteristics – Transmitter

$V_{CC3}=3.14V$ to $3.46V$, $T_C=0^{\circ}C$ to $70^{\circ}C$

Parameter	Symbol	Min	Typ	Max	Unit	Remarks
Input differential impedance	R_{IN}		100		Ω	1
Differential data input swing	V_{IN_PP}	120		1000	mV	
Transmit Disable Voltage	V_D	2		V_{CC}	V	2
Transmit Enable Voltage	V_{EN}	GND		GND+0.8	V	
Transmit Disable Assert Time				10	us	

Notes:

1. After internal AC coupling
2. Or open circuit

Electrical – Characteristics – Receiver**V_{CC3}=3.14V to 3.46V, T_C=0°C to 70°C**

Parameter	Symbol	Min	Typ	Max	Unit	Remarks
Differential data output swing	V _{OUT_PP}	340	650	850	mV	
Data output rise time/fall time (20%-80%)	t _r /t _f			40	ps	
LOS Fault	V _{LOS_A}	V _{CC} -0.5		V _{CC_HOST}	V	
LOS Normal	V _{LOS_D}	GND		GND+0.5	V	

Digital Diagnostic Functions

XFP-10G-SR-C-GEN incorporates an XFP compliant 2-wire management interface which is used for serial ID, digital diagnostics, and certain control functions. It is modeled on the SFF-8472 Rev 9.3 specification modified to accommodate a single 2-wire interface address. In addition to the basic I2C read/write functionality the modules support packet error checking that, when enabled, allows the host system to confirm the validity of any read data. Details of the protocol and interface are explicitly described in the MSA. The digital diagnostics provides real-time access to operating parameters via a 2-wire serial interface, including operating temperature, laser bias current, transmitted optical power, received optical power, and operating voltage.

Block-Diagram-of-Transceiver

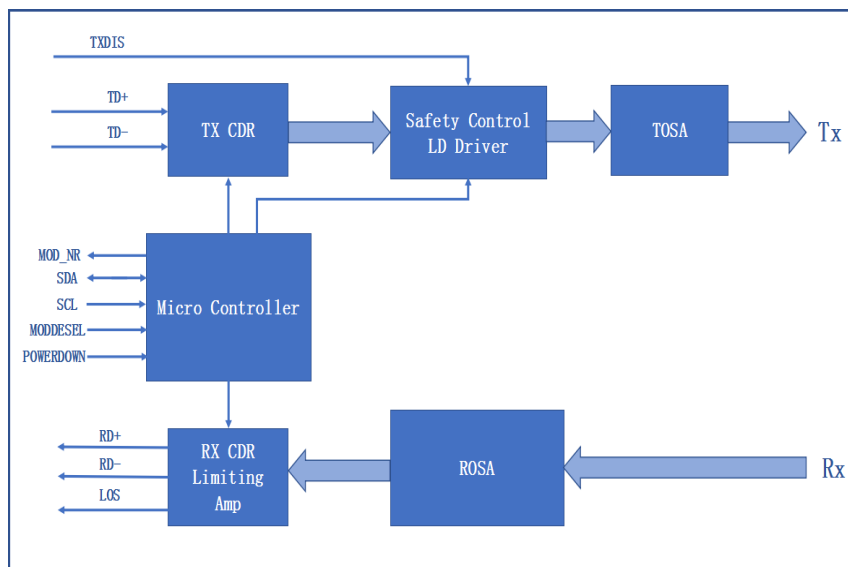

Functions Description

The transmitter consists of a laser driver chip and a TOSA (light-emitting component). The TOSA includes a laser and a backlight photodetection chip, and the input signal is connected to the laser driver chip. The laser driver chip supplies the bias current and the modulation current to the laser. The laser driver chip simultaneously uses an automatic optical power control (APC) feedback loop to maintain a constant average optical power of the laser output. The purpose is to eliminate the change of the output optical signal due to temperature changes and aging of the light source device. Clock Data Recovery Module (CDR) overcomes board and connector degradation by reshaping, regenerating, and reducing jitter. TX_DIS is an input pin. When TX_DIS is asserted High, the XFP module transmitter output must be turned off.

The receiver consists of a ROSA (light-receiving component) and a limiting amplifier chip, ROSA includes a PIN photodetector and a transimpedance amplifier chip. The ROSA detects the incident optical signal, converts the optical signal into an electrical signal, and outputs the electrical signal to the limiting amplifier. The limiting amplifier further amplifies the input signal and outputs a fixed amplitude electrical signal. Clock Data Recovery Module (CDR) overcomes board and connector degradation by reshaping, regenerating, and reducing jitter. The RX_LOS of an output pin, when LOS is high, it indicates insufficient optical power for reliable signal reception. MOD_NR is an output pin. When it is high, it indicates that the module detects the condition that invalidates the transmitter/receiver data. The transmission signal regulator loses lock, the transmitter laser fails, and the receiver signal regulator loses lock. Etc. The micro controller unit initializes the control register of laser driver, limiting amplifier and CDR. And monitors the running information from the laser driver, limiting amplifier and CDR. Then report these information to the customer.

Dimensions

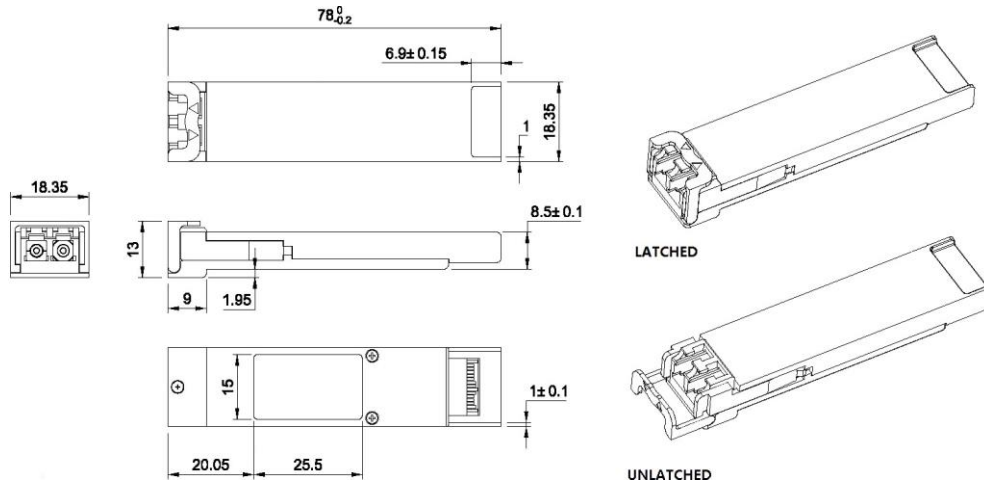

ALL DIMENSIONS ARE ± 0.2 mm UNLESS OTHERWISE SPECIFIED
UNIT: mm

Electrical Pad Layout

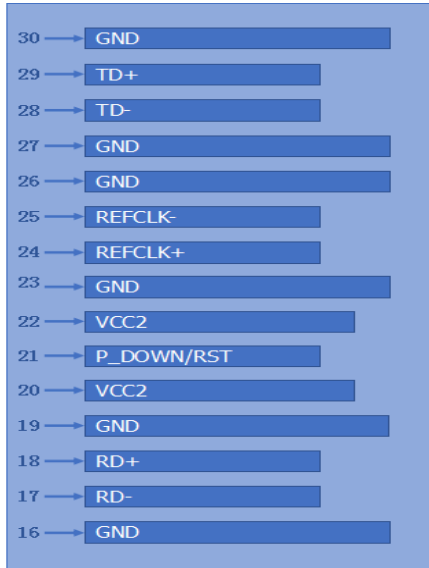

Top of Board

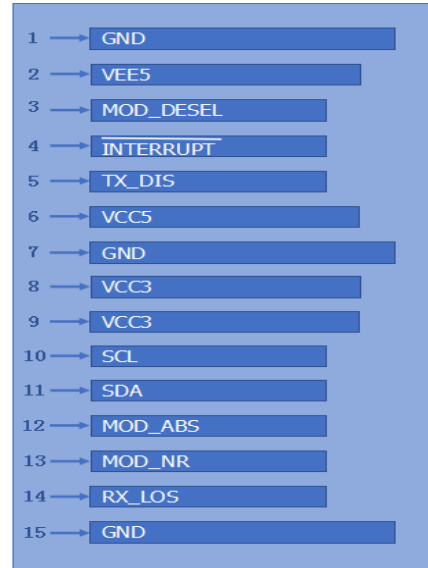

Bottom of Board

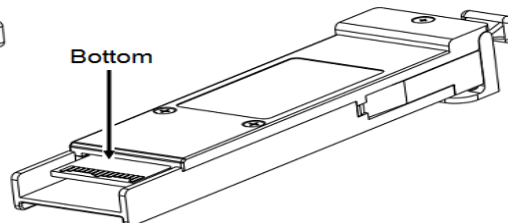
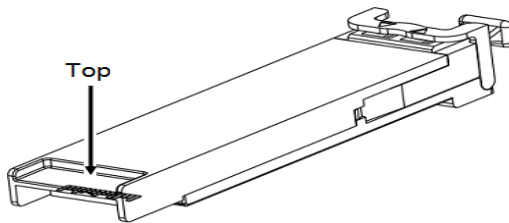

Pin Assignment - Pin1 to Pin30

PIN #	Symbol	Description	Remarks
1	GND	Module Ground	1
2	VEE5	Optional -5.2 Power Supply (Not required)	
3	Mod-Desel	Module De-select, when held low allows the module to respond to 2-wire serial interface commands	
4	$\overline{\text{Interrupt}}$	Indicates presence of an important condition which can be read over the serial 2-wire interface	2
5	TX_DISABLE	Transmitter Disable, Transmitter laser source turned off	
6	VCC5	+5V Power Supply	
7	GND	Module Ground	1
8	VCC3	+3.3V Power Supply	
9	VCC3	+3.3V Power Supply	
10	SCL	Serial 2-wire interface clock	2
11	SDA	Serial 2-wire interface data line	2
12	Mod_ABS	Module Absent; Indicates module is not present. Grounded in the module	2
13	Mod_NR	Module Not Ready; Indicates module operating fault	2
14	RX_LOS	Receiver Loss of Signal indicator	2
15	GND	Module Ground	1
16	GND	Module Ground	1
17	RD-	Receiver inverted data output	
18	RD+	Receiver non-inverted data output	
19	GND	Module Ground	1
20	VCC2	+1.8V Power Supply	
21	P_Down/RST	Power Down; When high, places the module in the low power stand-by mode and on the falling edge of P_Down initiates a module rest	
		Reset; The falling edge initiates a complete reset of the module including the 2-wire serial interface, equivalent to a power cycle	
22	VCC2	+1.8V Power Supply	
23	GND	Module Ground	1
24	RefCLK+	Reference Clock non-inverted input, AC coupled on the host board	
25	RefCLK-	Reference Clock inverted input, AC coupled on the host board	
26	GND	Module Ground	1
27	GND	Module Ground	1

28	TD-	Transmitter inverted data input	
29	TD+	Transmitter non-inverted data input	
30	GND	Module Ground	1

Notes:

1. Module ground pins (GND) are isolated from the module case and chassis ground within the module
2. Open collector, should be pulled up with 4.7k Ω -10k Ω on host board to a voltage between 3.15V and 3.6V

References

1. 10 Gigabit Small Form Factor Pluggable Module(XFP)Multi-Source Agreement(MSA), Rev4.5 – August 2005.