

## DATA SHEET

### QSFP10-PLR4-C-GEN

40Gb/s QSFP+ PSM4 10km Optical Transceiver

#### QSFP10-PLR4-C-GEN Overview

QSFP10-PLR4-C-GEN QSFP+ 40Gbps PSM4 optical transceivers are based on Ethernet IEEE 802.3ba standard and SFF-8436 standard. The QSFP+ full-duplex optical module offers 4 independent transmit and receive channels, each capable of 10.3125Gbps operation for an aggregate data rate of 41.25 Gbps 10km of single mode fiber. An optical fiber ribbon cable with an MPO/MTP connector can be plugged into the QSFP module receptacle.

#### Product Features

- Compliant with QSFP+ MSA (SFF-8436)
- Up to 11.2Gbps data rate per channel
- MPO optical connector
- Built-in digital diagnostic functions
- Up to 10km transmission on SMF
- Maximum 2W operation power
- RoHS-6 Compliant
- Operating temperature range: 0°C to 70°C

#### Applications

- 40G Ethernet
- Infiniband interconnects

## Ordering Information

Part Number	Product ID	Description	Color on Clasp
QSFP10-PLR4-C-GEN	M365901	40G QSFP+ PSM4 1310nm MPO Connectors, up to 10km on SMF, with DOM function	Blue
Notes : 1.Product ID is the abbreviated order number of the standard model of our products			
<b>For More Information:</b> SONGXIN TAIPEI TECH SOLUTIONS CO., LTD. Web: <a href="http://www.songxin.com.tw">www.songxin.com.tw</a> Email: <a href="mailto:oversea@songxin.cm.tw">oversea@songxin.cm.tw</a>			

## General Specifications

Parameter	Symbol	Min	Typ	Max	Unit	Remarks
Bit Error Rate	BER			$10^{-12}$		
Operating Temperature	T <sub>C</sub>	0		70	°C	1
Storage Temperature	T <sub>STO</sub>	-40		85	°C	2
Supply Current	I <sub>CC</sub>			600	mA	
Input Voltage	V <sub>CC</sub>	3.14	3.3	3.46	V	
Maximum Voltage	V <sub>MAX</sub>	0		3.8	V	3
Power Consumption	V <sub>CC</sub>			2	W	

**Notes:**

1. Case temperature
2. Ambient temperature
3. For electrical power interface

## Link Distances

Data Rate	Fiber Type	Distance Range (km)
40 Gb/s	9/125um SMF	10

## Optical – Characteristics – Transmitter

Parameter	Symbol	Min	Typ	Max	Unit	Remarks
Average Launch Power(Each Lane)	$P_{TX}$	-8.2		0.5	dBm	
Optical Center Wavelength	$\lambda_c$	1260		1360	nm	
Optical Modulation Amplitude(Each Lane)	OMA	-5.2		2.0	dB	
Extinction Ratio	ER	3.5			dB	
Side Mode Suppression Ratio	SMSR	30			dB	
Relative Intensity Noise	RIN			-128	dB/Hz	
Optical Return Loss Tolerance	TOL			12	dB	
Launch Power of OFF Transmitter(each lane)	$P_{OUT\_OFF}$			-30	dBm	

## Optical – Characteristics – Receiver

Parameter	Symbol	Min	Typ	Max	Unit	Remarks
Optical Center Wavelength	$\lambda_c$	1260		1360	nm	
Optical Input Power(each lane)	$P_{RX}$			0.5	dBm	1
Damage Threshold	P	3			dBm	
Receiver Sensitivity(each Lane)	$R_{X\_SEN1}$			-12.6	dBm	
LOS Assert	$LOS_A$	-30			dBm	
LOS De-Assert	$LOS_D$			-15	dBm	
LOS Hysteresis	$LOS_H$	0.5		6	dB	

**Notes:**

1. Average, Informative

## Electrical – Characteristics – Transmitter

Parameter	Symbol	Min	Typ	Max	Unit	Remarks
Input differential impedance	$R_{IN}$	90	100	110	$\Omega$	
Differential data input swing	$V_{IN\_PP}$	200		800	mV	
TP1/TP1a Interface	Compliant to IEEE802.3ba XLPPI					

## Electrical – Characteristics – Receiver

Parameter	Symbol	Min	Typ	Max	Unit	Remarks
Output differential impedance	$R_{OUT}$	90	100	110	$\Omega$	
Differential data output swing	$V_{OUT\_PP}$	400	600	850	mV	
TP4 Interface	Compliant to IEEE802.3ba XLPII					

## Dimensions

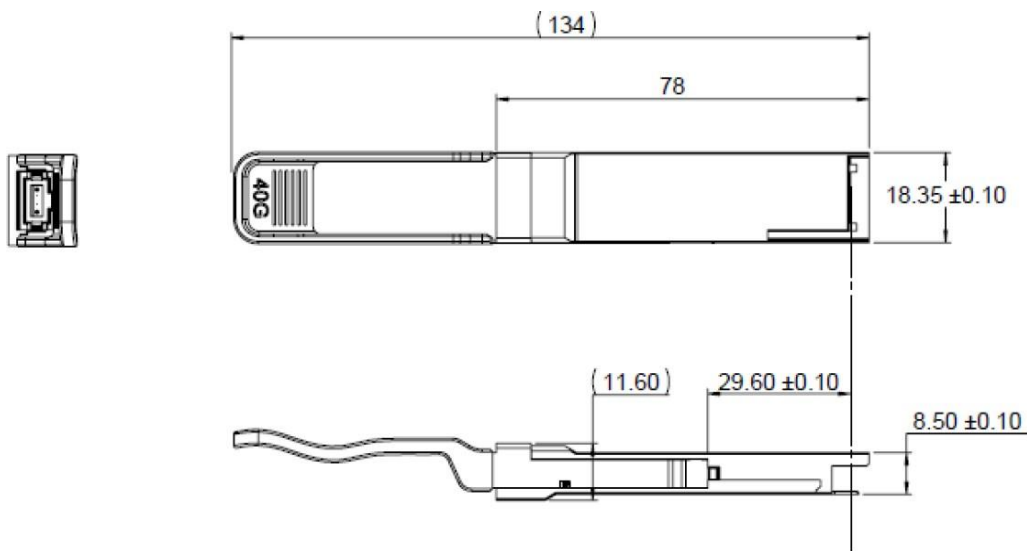

ALL DIMENSIONS ARE  $\pm 0.2$ mm UNLESS OTHERWISE SPECIFIED  
UNIT: mm

### Attention:

To minimize MPO connection induced reflections, an MPO receptacle with 8-degree angled end-face is utilized for this product. A female MPO connector with 8-degree endface should be used with this product.

## Electrical Pad Layout

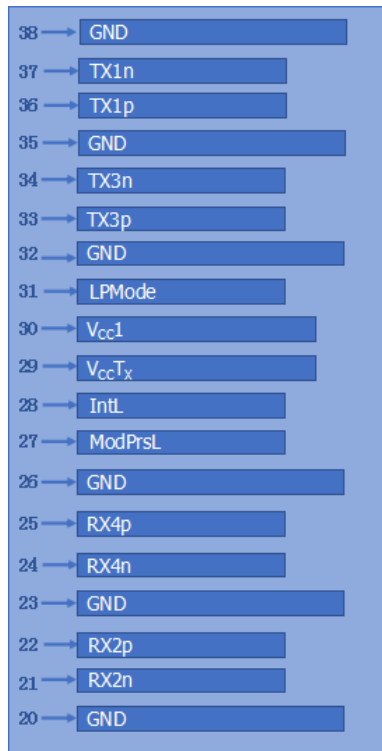

Top Board

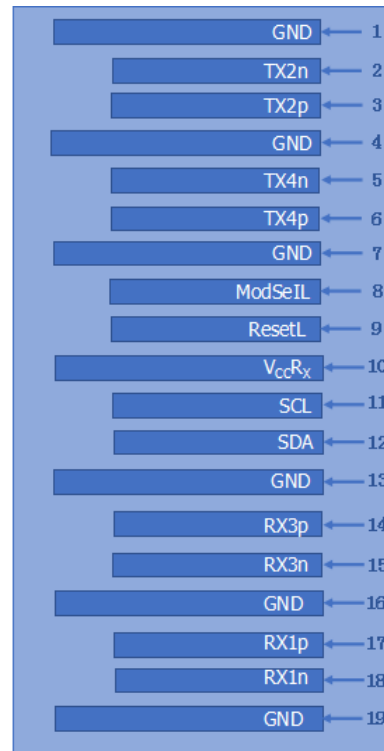

Bottom Board

## Pin Assignment

PIN #	Symbol	Description	Remarks
1	GND	Ground	5
2	Tx2n	Transmitter Inverted Data Input, LAN2	
3	Tx2p	Transmitter Non-Inverted Data Input, LAN2	
4	GND	Ground	5
5	Tx4n	Transmitter Inverted Data Input, LAN4	
6	Tx4p	Transmitter Non-Inverted Data Input, LAN4	
7	GND	Ground	5
8	ModSelL	Module select pin, the module responds to two-wire serial communication when low level	1
9	ResetL	Module Reset	2
10	V <sub>cc</sub> R <sub>X</sub>	+3.3V Power Supply Receiver	
11	SCL	2-wire serial interface clock	
12	SDA	2-wire serial interface data	
13	GND	Ground	5
14	Rx3p	Receiver Non-Inverted Data Output, LAN3	
15	Rx3n	Receiver Inverted Data Output, LAN3	
16	GND	Ground	5
17	Rx1p	Receiver Non-Inverted Data Output, LAN1	
18	Rx1n	Receiver Inverted Data Output, LAN1	
19	GND	Ground	5
20	GND	Ground	5
21	Rx2n	Receiver Inverted Data Output, LAN2	
22	Rx2p	Receiver Non-Inverted Data Output, LAN2	
23	GND	Ground	5
24	Rx4n	Receiver Inverted Data Output, LAN4	
25	Rx4p	Receiver Non-Inverted Data Output, LAN4	
26	GND	Ground	5
27	ModPrsL	The module is inserted into the indicate pin and grounded in the module.	3
28	IntL	Interrupt	4
29	V <sub>cc</sub> T <sub>X</sub>	+3.3V Power Supply transmitter	
30	V <sub>cc</sub> 1	+3.3V Power Supply	
31	LPMode	Low Power Mode	5
32	GND	Ground	5

33	Tx3p	Transmitter Non-Inverted Data Input, LAN3	
34	Tx3n	Transmitter Inverted Data Input, LAN3	
35	GND	Ground	5
36	Tx1p	Transmitter Non-Inverted Data Input, LAN1	
37	Tx1n	Transmitter Inverted Data Input, LAN1	
38	GND	Ground	5

**Notes:**

1. ModSelL is the input pin. The module responds to 2-wire serial communication commands when it is held low by the host. ModSelL allows multiple QSFP modules to be used on a single 2-wire interface bus. If ModSelL is High, the module will not respond to any 2-wire interface communication from the host. ModSelL has internal pull-up resistors in the module
2. The module restart pin, when the low level on the ResetL pin lasts longer than the minimum pulse length, resets the module and restores all user modules to their default state. When performing reset device, the host should ignore all status bits. Until the module reset interrupt is completed, please note that during hot plugging, the module will issue this information to complete the reset interrupt without resetting
3. This pin is active high, indicating that the module is running under a low power module.
4. IntL is the output pin, which is the open collector output and must be pulled up to Vcc on the motherboard. When it is low, it indicates that the module may malfunction. The host uses a 2-wire serial interface to identify the interrupt source
5. Circuit ground is internally isolated from chassis ground.

**References**

1. IEEE standard 802.3ba. IEEE Standard Department, 2010.
2. [QSFP+ 10Gbps 4X PLUGGABLE TRANSCEIVER – SFF-8436.](#)