

## DATA SHEET

### DAC-QSFP10-QSFP10-A-M-xxAWG-aa.aaM

QSFP+ Active Copper Cable Assembly

### DAC-QSFP10-QSFP10-A-M-xxAWG-aa.aaM Overview

DAC-QSFP10-QSFP10-A-M-xxAWG-aa.aaM QSFP+ (Quad Small Form-factor Pluggable Plus) active direct-attach copper cables are suitable for very short distances and offer a highly cost-effective way to establish a 40-Gigabit link between QSFP+ ports. QSFP+ are designed for a high density cabling interconnect system capable of delivering an aggregate data bandwidth of 40Gbps. This interconnect system is fully compliant with QSFP+ MSA. The QSFP+ cables support the bandwidth transmission requirements defined by IEEE802.3ba (40Gbps).

### Product Features

- Up to 40 Gb/s bi-directional data links
- Compliant with QSFP+ MSA specifications
- Fully Compliant with IEEE802.3ba and Infiniband QDR specifications
- 4 independent duplex channels operating at 10Gbps, also support for 2.5Gbps,5Gbps data rates
- All-metal housing for superior EMI performance
- Single power supply 3.3V
- low power consumption, less than 1.5W
- RoHS Compliant
- Operating temperature range: 0°C to 70°C

### Applications

- 40Gigabit Ethernet
- Serial Data Transmission
- QDR

## Ordering Information

Part Number	Description	Gauge	Length
DAC-QSFP10-QSFP10-A-M-xxAWG-aa.aaM	QSFP+ 40G Active Copper Cable Assembly, aa.aa $\leq$ 7	30AWG	$\leq$ 7m
DAC-QSFP10-QSFP10-A-M-xxAWG-aa.aaM	QSFP+ 40G Active Copper Cable Assembly, 7<aa.aa $\leq$ 10	28AWG	7m<length $\leq$ 10m
<p><b>Note:</b></p> <ol style="list-style-type: none"> <li>1. "A" indicates active cable</li> <li>2. "M" indicates built-in MCU</li> <li>3. "aa.aa" indicates the cable length in meters.</li> <li>4. The wire diameter of the products in the above list is the default value under different lengths. We can also provide other wire products to customers with special requirements.</li> </ol>			
<p><b>For More Information:</b>  SONGXIN TAIPEI TECH SOLUTIONS CO., LTD.  Web: <a href="http://www.songxin.com.tw">www.songxin.com.tw</a>  Email: <a href="mailto:oversea@songxin.com.tw">oversea@songxin.com.tw</a></p>			

## General Specifications

Parameter	Symbol	Min	Typ	Max	Unit	Remarks
Bit Error Rate	BER			$10^{-12}$		
Operating Temperature	T <sub>C</sub>	0		70	°C	1
Storage Temperature	T <sub>STO</sub>	-40		85	°C	2
Input Voltage	V <sub>CC</sub>	3.14	3.3	3.46	V	

**Notes:**

1. Case temperature
2. Ambient temperature

## Cable Specifications

Parameter	Symbol	Min	Typ	Max	Unit	Remarks
Wire Gauge		30AWG		28AWG	AWG	
Cable Impedance	Z	90	100	110	Ohm	

## Block Diagram of Transceiver

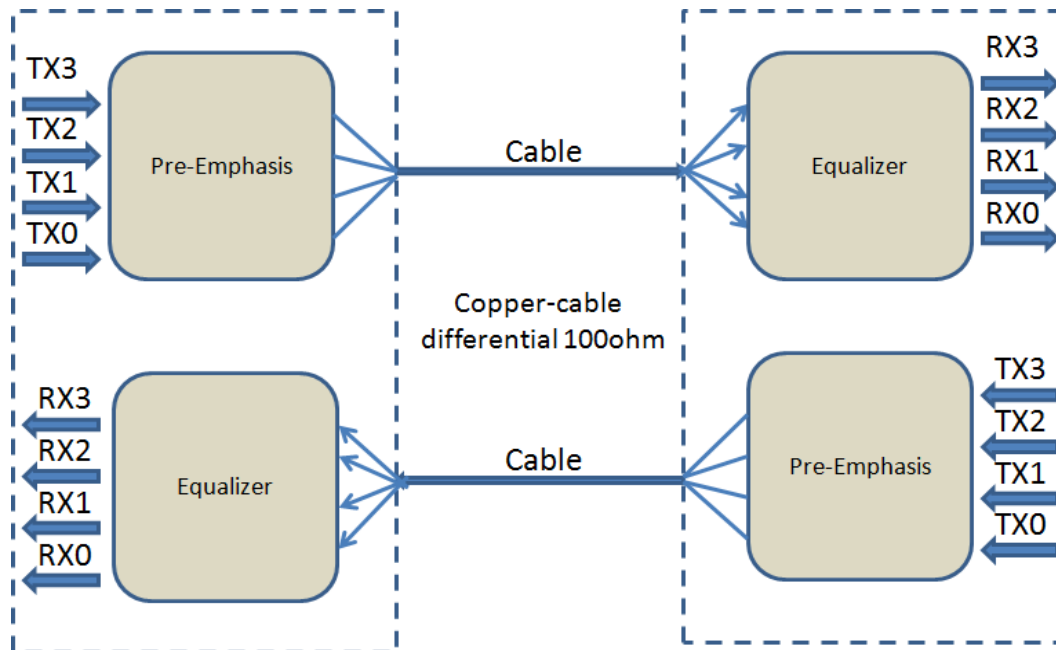

## Dimensions

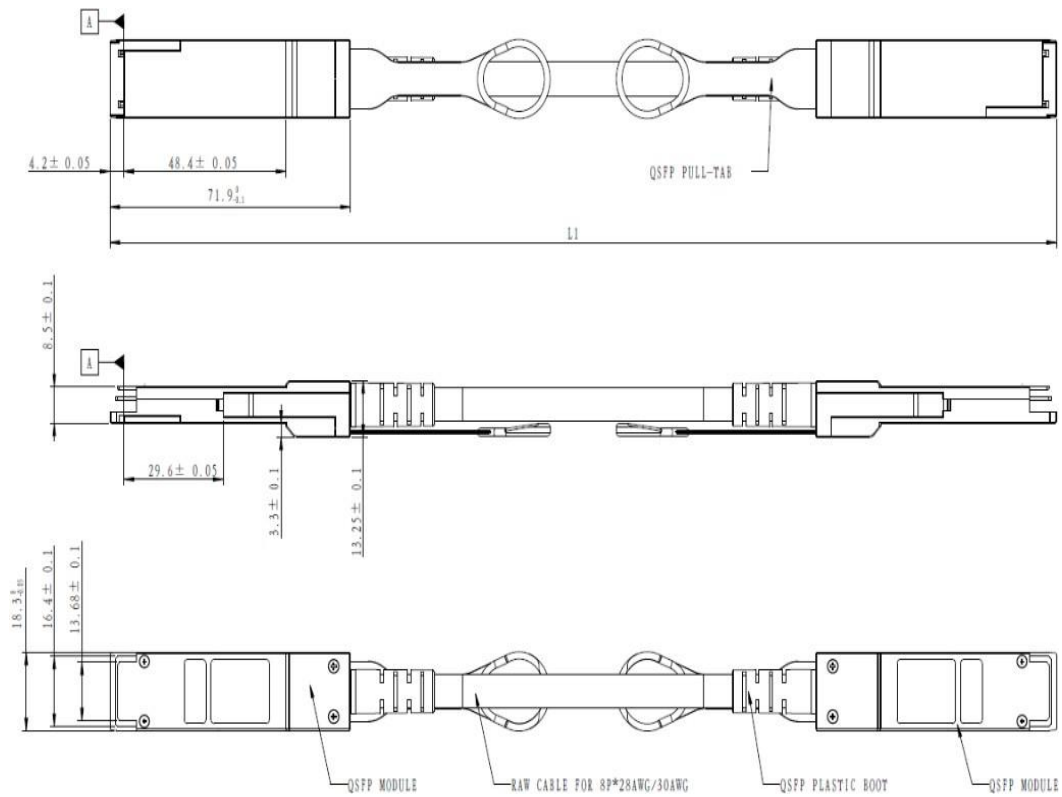

ALL DIMENSIONS ARE  $\pm 0.2$ mm UNLESS OTHERWISE SPECIFIED  
UNIT: mm

## Electrical Pad Layout

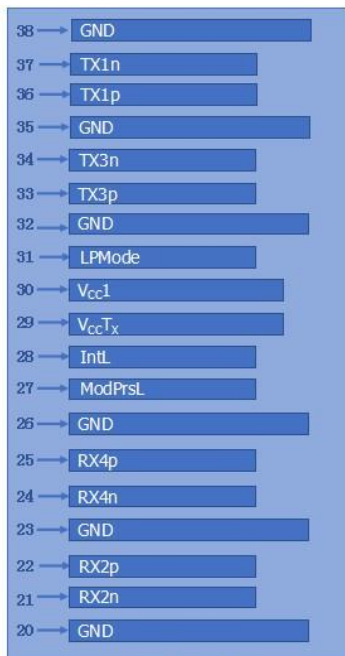

Top of Board

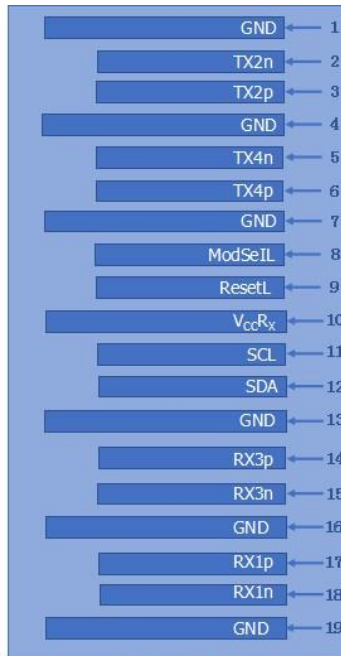

Bottom of Board

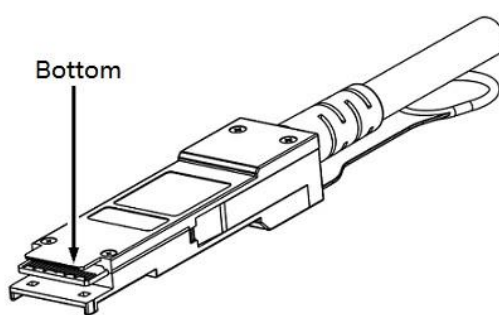
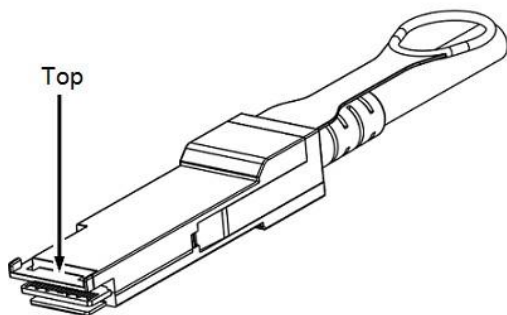

## Pin Assignment

PIN #	Symbol	Description	Remarks
1	GND	Ground	5
2	Tx2n	Transmitter Inverted Data Input, LAN2	
3	Tx2p	Transmitter Non-Inverted Data Input, LAN2	
4	GND	Ground	5
5	Tx4n	Transmitter Inverted Data Input, LAN4	
6	Tx4p	Transmitter Non-Inverted Data Input, LAN4	
7	GND	Ground	5
8	ModSelL	Module select pin, the module responds to two-wire serial communication when low level	1
9	ResetL	Module Reset	2
10	V <sub>cc</sub> R <sub>X</sub>	+3.3V Power Supply Receiver	
11	SCL	2-wire serial interface clock	
12	SDA	2-wire serial interface data	
13	GND	Ground	5
14	Rx3p	Receiver Non-Inverted Data Output, LAN3	
15	Rx3n	Receiver Inverted Data Output, LAN3	
16	GND	Ground	5
17	Rx1p	Receiver Non-Inverted Data Output, LAN1	
18	Rx1n	Receiver Inverted Data Output, LAN1	
19	GND	Ground	5
20	GND	Ground	5
21	Rx2n	Receiver Inverted Data Output, LAN2	
22	Rx2p	Receiver Non-Inverted Data Output, LAN2	
23	GND	Ground	5
24	Rx4n	Receiver Inverted Data Output, LAN4	
25	Rx4p	Receiver Non-Inverted Data Output, LAN4	
26	GND	Ground	5
27	ModPrsL	The module is inserted into the indicate pin and grounded in the module.	3
28	IntL	Interrupt	4
29	V <sub>cc</sub> T <sub>X</sub>	+3.3V Power Supply transmitter	
30	V <sub>cc</sub> 1	+3.3V Power Supply	
31	LPMODE	Low Power Mode	5
32	GND	Ground	5

33	Tx3p	Transmitter Non-Inverted Data Input, LAN3	
34	Tx3n	Transmitter Inverted Data Input, LAN3	
35	GND	Ground	5
36	Tx1p	Transmitter Non-Inverted Data Input, LAN1	
37	Tx1n	Transmitter Inverted Data Input, LAN1	
38	GND	Ground	5

**Notes:**

1. ModSelL is the input pin. The module responds to 2-wire serial communication commands when it is held low by the host. ModSelL allows multiple QSFP modules to be used on a single 2-wire interface bus. If ModSelL is High, the module will not respond to any 2-wire interface communication from the host. ModSelL has internal pull-up resistors in the module
2. The module restart pin, when the low level on the ResetL pin lasts longer than the minimum pulse length, resets the module and restores all user modules to their default state. When performing reset device, the host should ignore all status bits. Until the module reset interrupt is completed, please note that during hot plugging, the module will issue this information to complete the reset interrupt without resetting
3. This pin is active high, indicating that the module is running under a low power module.
4. IntL is the output pin, which is the open collector output and must be pulled up to Vcc on the motherboard. When it is low, it indicates that the module may malfunction. The host uses a 2-wire serial interface to identify the interrupt source
5. Circuit ground is internally isolated from chassis ground.

**References**

1. IEEE standard 802.3ba. IEEE Standard Department.
2. [QSFP+ 10Gbps 4X PLUGGABLE TRANSCEIVER -SFF-8436.](#)