

DATA SHEET

AOC-QSFP28-QSFP28-OM3-aaa.aaM

100Gb/s QSFP28 Active Optical Cable Transceiver

AOC-QSFP28-QSFP28-OM3-aaa.aaM Overview

AOC-QSFP28-QSFP28-OM3-aaa.aaM QSFP28 active optical cable transceivers are 4-channel active optical cable for QSFP28 application. This full-duplex optical assembly offers 4 independent transmit and receive channels, each capable of up to 25Gbps for an aggregate bandwidth of 100Gbps.

QSFP28 AOC can be used as a direct replacement for traditional copper cables with the added benefit of a lighter weight and smaller diameter solution for cable lengths from 1 to 70 meters.

Product Features

- Hot-pluggable QSFP28 form factor
- 4 high-speed full duplex channels
- Supports 103.1Gb/s aggregate bit rate
- 4x25Gbps 850nm VCSEL laser
- QSFP28 MSA compliant
- Low power dissipation:<3.5W per cable end (<2.5W with CDRs off)
- Cable lengths from 1 to 70 meters
- RoHS Compliant
- Operating temperature range: 0°C to70°C

Applications

- 100G Ethernet
- Infiniband interconnects

Ordering Information

Part Number	Description	Color on Clasp
AOC-QSFP28-QSFP28-OM3-aaa.aaM	100G QSFP28 Active Optical Cable (length from 1m to 70m)	Blue
For More Information: SONGXIN TAIPEI TECH SOLUTIONS CO., LTD. Web: www.songxin.com.tw Email: oversea@songxin.com.tw		

General Specifications

Parameter	Symbol	Min	Typ	Max	Unit	Remarks
Bit Error Rate	BER			10^{-12}		
Operating Temperature	T _C	0		70	°C	1
Storage Temperature	T _{STO}	-40		85	°C	2
Input Voltage	V _{CC}	3.14	3.3	3.46	V	
Maximum Voltage	V _{MAX}	-0.5		3.6	V	3
Minimum bending radius	R	30			mm	

Notes:

1. Case temperature
2. Ambient temperature
3. For electrical power interface

AOC Electrical Input Requirements

Parameter	Symbol	Min	Typ	Max	Unit	Remarks
Data Rate Per Channel	DR		25.78125		Gb/s	
Differential Input Amplitude	V_{IN_PP}			900	mV	
Input AC Common Mode Voltage	V_{CM}	-300		2800	mV	
Differential Termination Resistance Mismatch				10	%	
Differential Return Loss	SDD22				dB	1
Common Mode to Differential conversion and Differential to Common Mode conversion	SDC22, SCD22				dB	1
Transition Time(20%-80%)	t_r / t_f	10			ps	

Notes:

1. Per OIF CEI-28G-VSR and CAUI-4 requirements

AOC Electrical Output Requirements

Parameter	Symbol	Min	Typ	Max	Unit	Remarks
Data Rate Per Channel	DR		25.78125		Gb/s	
Differential Output Amplitude	V_{OUT_PP}			900	mV	
Output AC Common Mode Voltage	V_{CM}	-350		2850	mV	
Differential Termination Resistance Mismatch				10	%	
Differential Return Loss	SDD22				dB	1
Common Mode to Differential conversion and Differential to Common Mode conversion	SDC22, SCD22				dB	1
Transition Time (20%-80%)	t_r / t_f	9.5			ps	

Notes:

1. Per OIF CEI-28G-VSR and CAUI-4 requirements

Block-Diagram-of-Transceiver

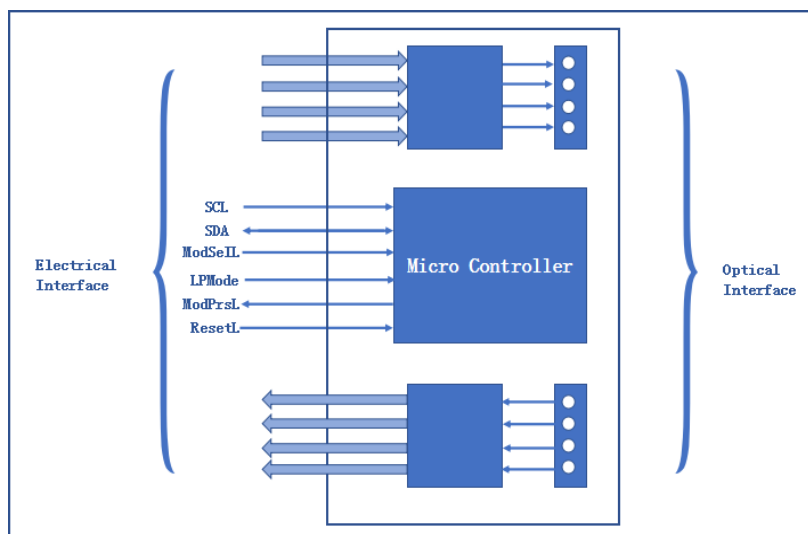

Functions Description

The QSFP28 AOC has miniature optical engine embedded into each end of the cable assembly. The engines interconnect 4 independent transmit/receive lanes.

A functional block diagram of the engine is shown in the above Figure. The transmitter sections consist of a 4-channel VCSEL array, a 4-channel input buffer and laser driver.

An on board micro-controller provides control, diagnostic and monitoring for the cable functions, as well as the external I2C serial communication interface.

The Receiver section consists of a 4-channel PIN photodiode array, a 4-channel TIA array, and a 4-channel output buffer.

Dimensions

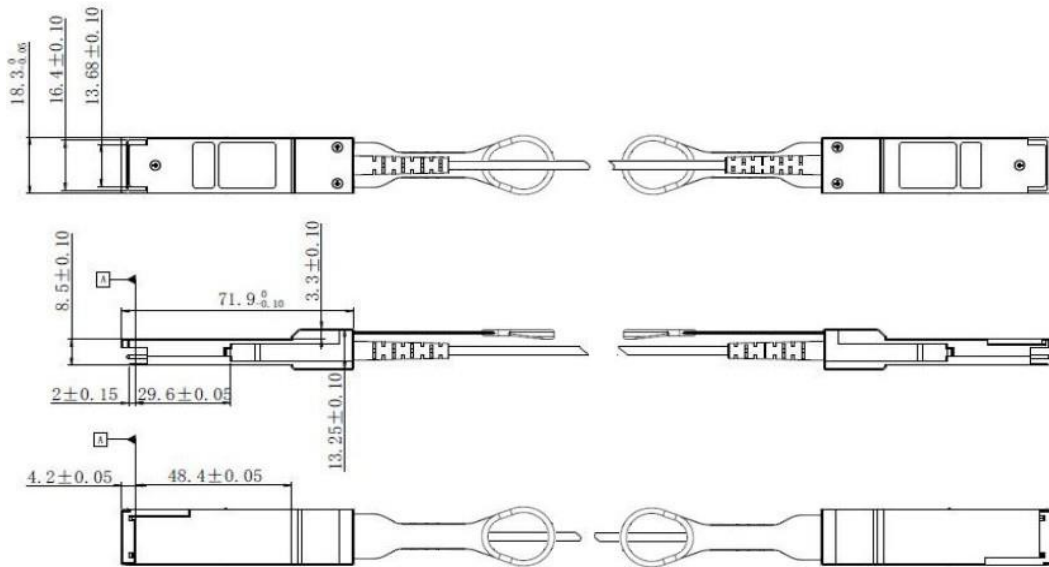

ALL DIMENSIONS ARE ± 0.2 mm UNLESS OTHERWISE SPECIFIED
UNIT: mm

Electrical Pad Layout

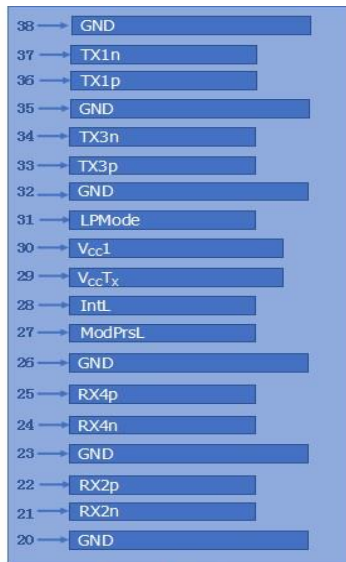

Top of Board



Bottom of Board

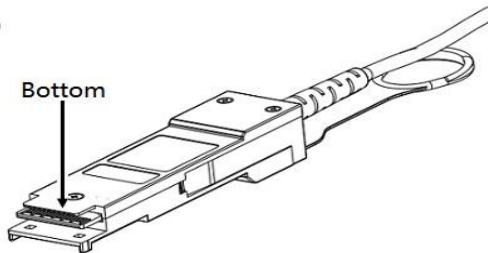
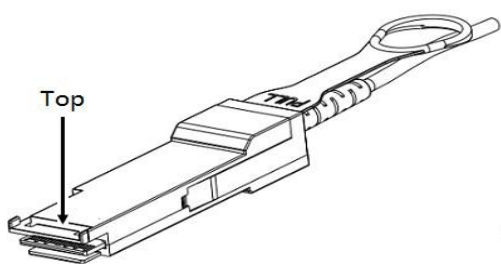

Pin Assignment

PIN #	Symbol	Description	Remarks
1	GND	Ground	5
2	Tx2n	Transmitter Inverted Data Input, LAN2	
3	Tx2p	Transmitter Non-Inverted Data Input, LAN2	
4	GND	Ground	5
5	Tx4n	Transmitter Inverted Data Input, LAN4	
6	Tx4p	Transmitter Non-Inverted Data Input, LAN4	
7	GND	Ground	5
8	ModSelL	Module select pin, the module responds to two-wire serial communication when low level	1
9	ResetL	Module Reset	2
10	V _{cc} R _X	+3.3V Power Supply Receiver	
11	SCL	2-wire serial interface clock	
12	SDA	2-wire serial interface data	
13	GND	Ground	5
14	Rx3p	Receiver Non-Inverted Data Output, LAN3	
15	Rx3n	Receiver Inverted Data Output, LAN3	
16	GND	Ground	5
17	Rx1p	Receiver Non-Inverted Data Output, LAN1	
18	Rx1n	Receiver Inverted Data Output, LAN1	
19	GND	Ground	5
20	GND	Ground	5
21	Rx2n	Receiver Inverted Data Output, LAN2	
22	Rx2p	Receiver Non-Inverted Data Output, LAN2	
23	GND	Ground	5
24	Rx4n	Receiver Inverted Data Output, LAN4	
25	Rx4p	Receiver Non-Inverted Data Output, LAN4	
26	GND	Ground	5
27	ModPrsL	The module is inserted into the indicate pin and grounded in the module.	3
28	IntL	Interrupt	4
29	V _{cc} T _X	+3.3V Power Supply transmitter	
30	V _{cc} 1	+3.3V Power Supply	
31	LPMODE	Low Power Mode	5
32	GND	Ground	5

33	Tx3p	Transmitter Non-Inverted Data Input, LAN3	
34	Tx3n	Transmitter Inverted Data Input, LAN3	
35	GND	Ground	5
36	Tx1p	Transmitter Non-Inverted Data Input, LAN1	
37	Tx1n	Transmitter Inverted Data Input, LAN1	
38	GND	Ground	5

Notes:

1. ModSelL is the input pin. The module responds to 2-wire serial communication commands when it is held low by the host. ModSelL allows multiple QSFP modules to be used on a single 2-wire interface bus. If ModSelL is High, the module will not respond to any 2-wire interface communication from the host. ModSelL has internal pull-up resistors in the module
2. The module restart pin, when the low level on the ResetL pin lasts longer than the minimum pulse length, resets the module and restores all user modules to their default state. When performing reset device, the host should ignore all status bits. Until the module reset interrupt is completed, please note that during hot plugging, the module will issue this information to complete the reset interrupt without resetting
3. This pin is active high, indicating that the module is running under a low power module.
4. IntL is the output pin, which is the open collector output and must be pulled up to Vcc on the motherboard. When it is low, it indicates that the module may malfunction. The host uses a 2-wire serial interface to identify the interrupt source
5. Circuit ground is internally isolated from chassis ground.

References

1. IEEE standard 802.3bm. IEEE Standard Department. 2. [QSFP28 4X PLUGGABLE TRANSCEIVER –SFF-8665.](#)