

## DATA SHEET

### **AOC-SFP10-SFP10-OM3-aaa.aaM**

10Gb/s SFP+ Active Optical Cable

### **AOC-SFP10-SFP10-OM3-aaa.aaM Overview**

AOC-SFP10-SFP10-OM3-aaa.aaM SFP+ active optical cables are based on 10 Gigabit Ethernet and SFF-8431 standard, and provide a quick and reliable interface for the 10G Ethernet application. The digital diagnostic functions are available via 2-wire serial bus specified in SFF-8472.

### **Product Features**

- Up to 10.5 Gb/s bi-directional data links
- Compliant with IEEE 802.3ae
- Compliant with SFF-8431
- Hot-pluggable SFP+ footprint
- 850nm VCSEL laser transmitter and PIN receiver
- Built-in digital diagnostic functions
- Up to 300m on OM3 MMF
- Low power consumption (Module work consumption <1W)
- Single power supply 3.3V
- RoHS Compliant
- Operating temperature range ( Case Temperature ) : 0°C to 70°C

### **Applications**

- 10G Ethernet Data Center Intra-Rack and Inter-Rack links

## Ordering Information

Part Number	Product ID	Description	Color on Clasp
AOC-SFP10-SFP10-OM3-aaa.aaM	M253801	10G SFP+ Active Optical Cable up to 300m on OM3 MMF, with DOM function	Blue
Notes : 1. Product ID is the abbreviated order number of the standard model of our products 2. "aaa.aa" indicates the cable length in meter, $1.00 \leq \text{aaa.aa} \leq 300.00$			
<b>For More Information:</b> SONGXIN TAIPEI TECH SOLUTIONS CO., LTD. Web: <a href="http://www.songxin.com.tw">www.songxin.com.tw</a> Email: <a href="mailto:oversea@songxin.com.tw">oversea@songxin.com.tw</a>			

## General Specifications

Parameter	Symbol	Min	Typ	Max	Unit	Remarks
Data Rate	DR		10.3125		Gb/s	1
Bit Error Rate	BER			$10^{-12}$		
Operating Temperature	T <sub>C</sub>	0		70	°C	2
Storage Temperature	T <sub>STO</sub>	-40		85	°C	3
Supply Current	I <sub>CC</sub>		180	290	mA	4
Input Voltage	V <sub>CC</sub>	3.14	3.3	3.46	V	
Maximum Voltage	V <sub>MAX</sub>	-0.5		4	V	4

**Notes:**

1. IEEE 802.3ae
2. Case temperature
3. Ambient temperature
4. For electrical power interface

**Electrical – Characteristics – Transmitter** **$V_{CC}=3.14V$  to  $3.46V$ ,  $T_C=0^{\circ}C$  to  $70^{\circ}C$** 

Parameter	Symbol	Min	Typ	Max	Unit	Remarks
Input differential impedance	$R_{IN}$		100		$\Omega$	1
Differential data input swing	$V_{IN\_PP}$	180		700	mV	
Transmit Disable Voltage	$V_D$	2		$V_{CC}$	V	
Transmit Enable Voltage	$V_{EN}$	$V_{EE}$		$V_{EE}+0.8$	V	

**Notes:**

1. Non-condensing

**Electrical – Characteristics – Receiver** **$V_{CC}=3.14V$  to  $3.46V$ ,  $T_C=0^{\circ}C$  to  $70^{\circ}C$** 

Parameter	Symbol	Min	Typ	Max	Unit	Remarks
Differential data output swing	$V_{OUT\_PP}$	300		850	mV	
Data output rise time (20%-80%)	$t_r$	30			ps	
Data output fall time(20%-80%)	$t_f$	30			ps	
LOS Fault	$V_{LOS\_A}$	2		$V_{CC\_HOST}$	V	
LOS Normal	$V_{LOS\_D}$	$V_{EE}$		$V_{EE}+0.5$	V	

## A0H Register Description

IIC Addr	Size	Name	Description	Values(HEX)
0	1	Identifier	SFP+	03
1	1	Extended Identifier	Use IIC interface	04
2	1	Connector	Optical Pigtail	0B
3-10	8	Transceiver	Active Cable	00 00 00 00 00 08 00 00
11	1	Encoding	64B/66B	06
12	1	BR, Nominal	Nominal Bit Rate 10.3Gb/s	67
13	1	Rate Identifier	Without rate selection function	00
14	1	Length(9μm)-km	Link Length / SMF = N/A	00
15	1	Length (9μm)-100m	Link Length / SMF = N/A	00
16	1	Length (50μm)-10m	50μm MMF Link Length = 80m	00
17	1	Length (62.5μm)-10m	62.5μm MMF Link Length = 20m	00
18	1	Length (Copper)	Copper Link Length = N/A	00
19	1	Length (50μm)-10m	50μm MMF Link Length = 300m	1E
20-35	16	Vendor name	SONGXIN	ASCII Format
36	1	Transceiver	Reserved	00
37-39	3	Vendor OUI	Without vendor OUI	00 00 00
40-55	16	Vendor PN	Part number in the Ordering Information	Programmed by Factory
56-59	4	Vendor Revision Number	Manufacturer product version number	Programmed by Factory
60-61	2	Wavelength	Laser Wavelength	03 52
62	1	Reserved	Reserved	00
63	1	CC_BASE	Checksum of bytes 0-62	Programmed by Factory
64-65	2	Transceiver Options	Indicates which optional transceiver signals are implemented	00 00
66	1	BR, max	NA	00
67	1	BR, min	NA	00
68-83	16	Vendor SN	Manufacturer serial number	Programmed by Factory
84-91	8	Date code	Date code	Programmed by Factory
92	1	Monitoring Type	Internal calibration of DOM RxPower measurement using average optical power	68
93	1	Enhanced Options	1.Monitor Alarm and Warning of TxPower and RxPower 2.Tx_DIS Monitor and Control 3.Rx_LOS Monitor 4.Tx_FAULT Monitor	F0
94	1	Compliance	Revision Implemented	08
95	1	CC_EXT	Check sum of bytes 64-94	Programmed by Factory
96-127	32	Vendor Specific	Vendor Specific Area	Programmed by Factory
128-255	128	Vendor Specific	Vendor Specific Area	Programmed by Factory

## Digital Diagnostic Functions

AOC-SFP10-SFP10-OM3-aaa.aaM supports the 2-wire serial communication protocol as defined in SFF-8472. Digital diagnostic information is accessible over the 2-wire interface at the address 0xA2. Digital diagnostics for AOC-SFP10-SFP10-OM3-aaa.aaM are internally calibrated by default. The internal micro control unit accesses the device operating parameters in real time, such as transceiver temperature, laser bias current, transmitted optical power, received optical power and transceiver supply voltage. The module implements the alarm function of the SFF-8472, alerts the user when a particular operating parameter exceeds the factory-set normal range.

## Block-Diagram-of-Transceiver

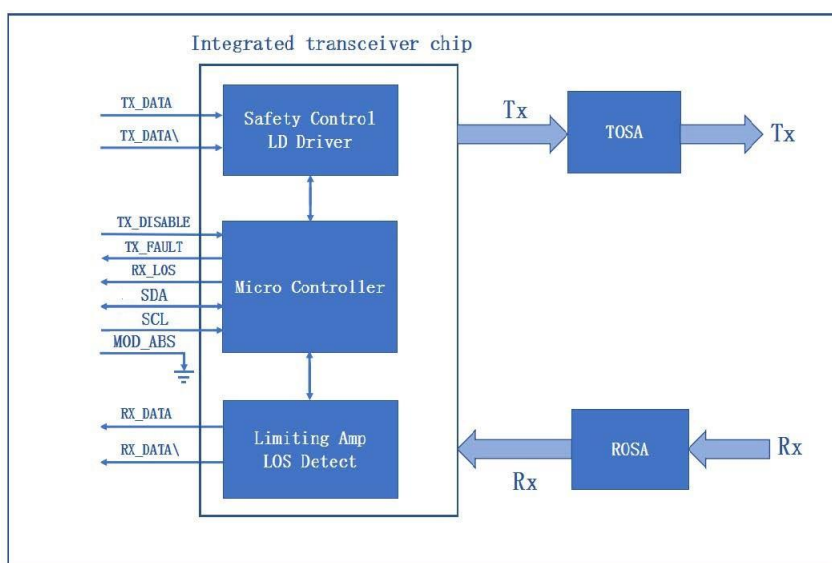

## Functions Description

The transmitter is mainly composed of a laser driver part of the intelligent transceiver chip and a TOSA (light-emitting component), the TOSA includes a 850nm VCSEL laser and a backlight photodetection chip. When the module is working, the input signal is connected to the intelligent transceiver chip, at this time, the laser driver of the intelligent transceiver chip supplies the bias current and the modulation current to the laser. The intelligent transceiver chip simultaneously uses an automatic optical power control (APC) feedback loop to maintain a constant average optical power of the laser output. The purpose is to eliminate the change of the output optical signal due to temperature changes and aging of the light source device. When the transmitter enable pin (TX\_Disable) is high (TTL logic "1"), the laser output is turned off. When TX\_Disable is low (TTL logic "0"), the laser will turn on within 1ms. When the transmitter fault signal (TX\_Fault) is reported as high, indicates a transmitter failure caused by the transmitter's bias current or transmitted optical power or laser tube temperature exceeding a preset alarm threshold. Low indicates normal operation.

The receiver is mainly composed of a limiting amplifier part of the intelligent transceiver chip and a ROSA (light-receiving component), the ROSA includes a PIN photodetector and a transimpedance amplifier chip. When the ROSA detects the incident light signal, it will be converted into a photo-generated current by the PIN photodetector. The photo-generated current is converted into an electrical signal after passing through the transimpedance amplifier. The electrical signal is further amplified by the limiting amplifier of the intelligent transceiver chip, then outputs a fixed-amplitude electrical signal to the host. When the amplitude of the electrical signal received from the incident light conversion of the opposite optical transceiver module is lower than the set threshold, the module reports that the received signal is lost, the RX\_LOS pin is high (logic "1"), which can be used to diagnose whether the physical signal is normal. The signal is operated in TTL level. The microprocessor inside the module monitors the module's operating voltage, temperature, transmitted optical power, received optical power, and laser bias current value in real time. The host acquires this information over a 2-wire serial bus.

After the module is powered on, the read value of the security level access registers 7BH ~ 7EH of A2H is replaced with 0x00. After the content of this group of registers is updated, the read value is the last written value. The security level 1 password of this module is 0x00001011. The method to enter the security level 1 working state is to convert and write the security level 1 password in the A2H 7BH ~ 7EH registers of the module, namely 0x00, 0x00, 0x10, 0x11. After entering the security level 1 working state, the user can directly write to the content of the A0H device address, or modify the content of the A2H 7FH table selection register to write to the contents of Table 00 or Table 01. And this version of the module does not support users to modify the security level 1 password.

**Optical Cable Details**

Parameter	Min	Typ	Max	Unit	Remarks
Jacket Material		LSZH			
Jacket Color		Aqua Green			We can provide according to the needs of customers
Flammability Rating		OFN			We can provide according to the needs of customers
Outer Diameter	2.8	3.0	3.2	mm	
Tensile Load(Short Term)			200	N	
Tensile Load(Long Term)			100	N	
Crush Resistance	10			N/mm	IEC 60794-1-21
Impact Resistance	0.5			N.m	IEC 60794-1-21
Flexing	300			Cycles	IEC 60794-1-21
Twist Bend					IEC 60794-1-21
Cable to SFP+ Plug Connection			90	N	
Bend Radius(Short Term)	25			mm	
Bend Radius(Long Term)	30			mm	

## Product Weight

The weight of AOC-SFP10-SFP10-OM3-1M : 53g/pcs

The weight of every meter of optical cable : 6.4g/M

For example:the weight of AOC-SFP10-SFP10-OM3-5M-C1C1C is: $53 + (5-1) * 6.4 = 78.6g$

## Dimensions

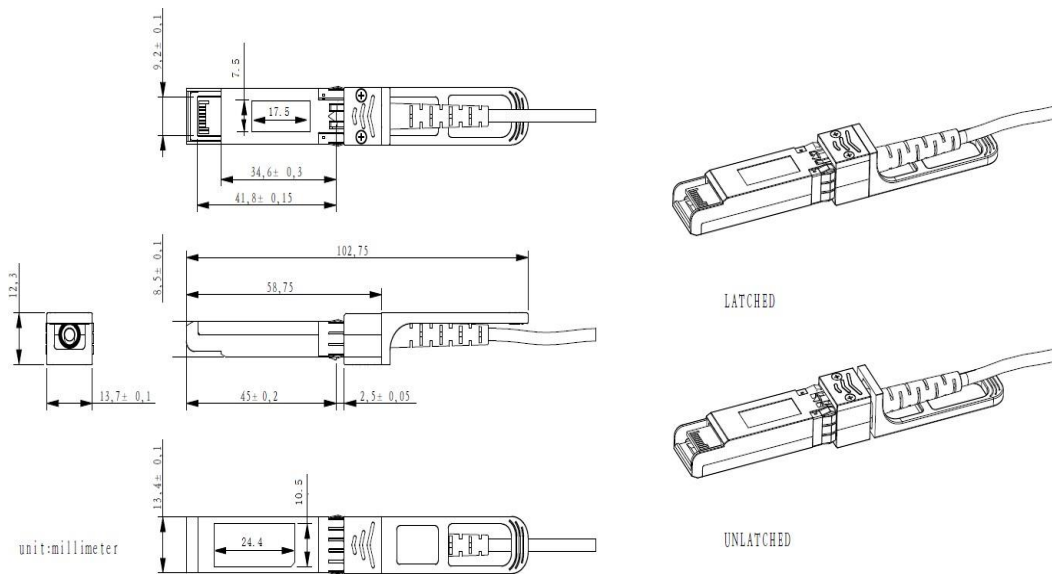

ALL DIMENSIONS ARE  $\pm 0.2mm$  UNLESS OTHERWISE SPECIFIED  
UNIT: mm



## Electrical Pad Layout

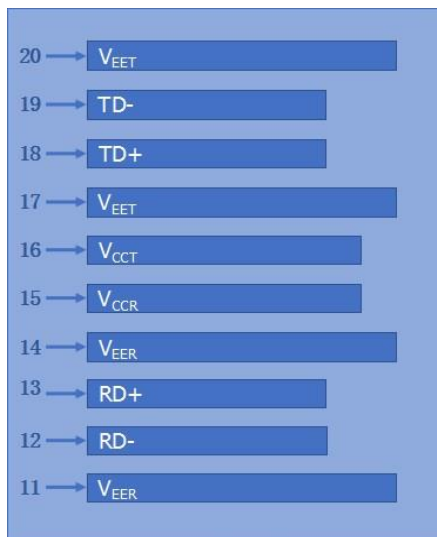

Top of Board

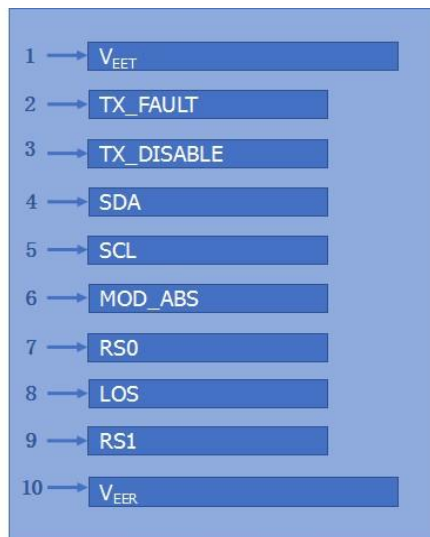

Bottom of Board

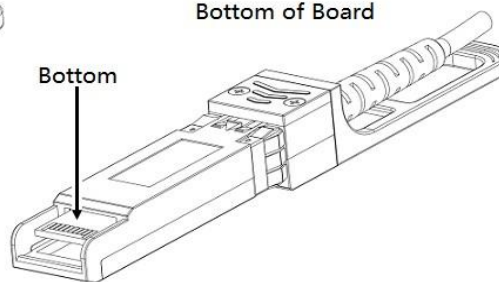
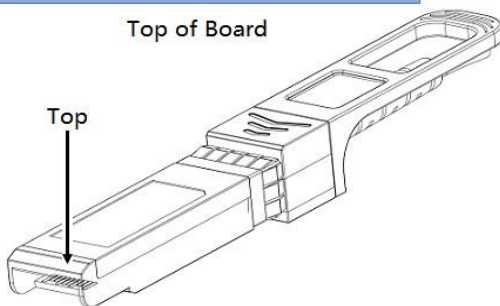

## Pin Assignment

PIN #	Symbol	Description	Remarks
1	V <sub>EET</sub>	Transmitter ground (common with receiver ground)	1
2	TX_FAULT	Transmitter Fault	
3	TX_DISABLE	Transmitter Disable. Laser output disabled on high or open	2
4	SDA	2-wire Serial Interface Data Line	3
5	SCL	2-wire Serial Interface Clock Line	3
6	MOD_ABS	Module Absent. Grounded within the module	3
7	RS0	No connection required	
8	LOS	Loss of Signal indication. Logic 0 indicates normal operation	4
9	RS1	No connection required	1
10	V <sub>EER</sub>	Receiver ground (common with transmitter ground)	1
11	V <sub>EER</sub>	Receiver ground (common with transmitter ground)	1
12	RD-	Receiver Inverted DATA out. AC coupled	
13	RD+	Receiver Non-inverted DATA out. AC coupled	
14	V <sub>EER</sub>	Receiver ground (common with transmitter ground)	1
15	V <sub>CCR</sub>	Receiver power supply	
16	V <sub>CCT</sub>	Transmitter power supply	
17	V <sub>EET</sub>	Transmitter ground (common with receiver ground)	1
18	TD+	Transmitter Non-Inverted DATA in. AC coupled	
19	TD-	Transmitter Inverted DATA in. AC coupled	
20	V <sub>EET</sub>	Transmitter ground (common with receiver ground)	1

**Notes:**

1. Circuit ground is isolated from chassis ground
2. Disabled: T<sub>DIS</sub>>2V or open, Enabled: T<sub>DIS</sub><0.8V
3. Should Be pulled up with 4.7k - 10k ohm on host board to a voltage between 2V and 3.6V
4. LOS is open collector output

## References

1. IEEE standard 802.3ae. IEEE Standard Department, 2005.
2. Enhanced 8.5 and 10 Gigabit Small Form Factor Pluggable Module "SFP+" – SFF-8431.
3. Digital Diagnostics Monitoring Interface for Optical Transceivers – SFF-8472.