

## DATA SHEET

### SFP-25G-LR-C-GEN

25Gb/s SFP28 LR 10km Transceiver

### SFP-25G-LR-C-GEN Overview

SFP-25G-LR-C-GEN optical transceivers are based on 25G Ethernet IEEE 802.3cc standard. They are compliant with SFF-8402, SFF-8432 and SFF-8472, providing a fast and reliable interface for 25G Ethernet applications. The product implements digital diagnostics via a 2-wire serial bus and is compliant with the SFF-8472 standard.

### Product Features

- Operating data rate support 24.3Gbps to 26.5Gbps
- Compliant with IEEE 802.3cc
- Compliant with SFF-8402
- Compliant with SFF-8432
- Compliant with SFF-8472
- Internal CDR on both Transmitter and Receiver channel
- Hot-pluggable SFP28 footprint
- 1310nm DFB laser transmitter and PIN PD Receiver
- Duplex LC connector
- Built-in digital diagnostic functions
- Up to 10km on SMF
- Single power supply 3.3V
- RoHS Compliant
- Operating temperature range ( Case Temperature ) : C Grade 0°C to 70°C  
I Grade -40°C to 85°C



### Applications

- 25GBASE-LR Ethernet
- CPRI and eCPRI Wireless Networks

## Ordering Information

Part Number	Description	Bail Color
SFP-25G-LR-C-GEN	25GBASE-LR SFP28 1310nm LC Connectors 10km on SMF, Commercial Temperature	Blue
SFP-25G-LR-I-GEN	25GBASE-LR SFP28 1310nm LC Connectors 10km on SMF, Industrial Temperature	Blue
<b>For More Information:</b> SONGXIN TAIPEI TECH SOLUTIONS CO., LTD. Web: <a href="http://www.songxin.com.tw">www.songxin.com.tw</a> Email: <a href="mailto:oversea@songxin.com.tw">oversea@songxin.com.tw</a>		

## General Specifications

Parameter	Symbol	Min	Typ	Max	Unit	Remarks
Data Rate	DR	24.3		26.5	Gb/s	1
Bit Error Rate	BER			$5 \times 10^{-5}$		2
Operating Temperature	T <sub>C</sub>	0		70	°C	3
		-40		85	°C	3
Storage Temperature	T <sub>STO</sub>	-40		85	°C	4
Supply Current	I <sub>CC</sub>		200	400	mA	5
Input Voltage	V <sub>CC</sub>	3.14	3.3	3.46	V	
Maximum Voltage	V <sub>MAX</sub>	-0.5		4	V	5

### Notes:

1. IEEE 802.3cc
2. Measured with data rate at 25.78Gb/s, PRBS 2<sup>31</sup>-1
3. Case temperature
4. Ambient temperature
5. For electrical power interface

## Link Distances

Data Rate	Fiber Type	Distance Range (km)	Remarks
25.78 Gb/s	9/125um SMF	10	1

### Notes:

1. This module requires RS-FEC on the host ports for operation at 25G

## Optical Characteristics – Transmitter

$V_{CC}=3.14V$  to  $3.46V, T_C$

Parameter	Symbol	Min	Typ	Max	Unit	Remarks
Output Optical Power	$P_{TX}$	-7		2	dBm	1
Optical Center Wavelength	$\lambda_c$	1295	1310	1325	nm	
Transmitter and Dispersion Penalty	TDP			2.7	dB	
Extinction Ratio	ER	3.5			dB	
Spectral Width (-20dB)	$\Delta\lambda$			1	nm	
Side Mode Suppression Ratio	SMSR	30			dB	
Transmitter Reflectance				-12	dB	
Launch Power of OFF Transmitter	$P_{OUT\_OFF}$			-30	dBm	1

**Notes:**

1. Average

## Optical – Characteristics – Receiver

$V_{CC}=3.14V$  to  $3.46V, T_C$

Parameter	Symbol	Min	Typ	Max	Unit	Remarks
Optical Center Wavelength	$\lambda_c$	1260		1360	nm	
Receive Overload	$P_{OL}$	2			dBm	
Receiver Sensitivity (OMA)@ 25.78Gb/s	$R_{X\_SEN}$			-13.3	dBm	1
Receiver Reflectance	$TR_{RX}$			-26	dB	
LOS Assert	$LOS_A$	-30			dBm	
LOS De-Assert	$LOS_D$			-17	dBm	
LOS Hysteresis	$LOS_H$	0.5			dB	

**Notes:**

1. Measured with data rate at 25.78Gb/s, PRBS  $2^{31}-1$ , BER  $5 \times 10^{-5}$

**Electrical Characteristics – Transmitter** **$V_{CC}=3.14V$  to  $3.46V, T_C$** 

Parameter	Symbol	Min	Typ	Max	Unit	Remarks
Input differential impedance	$R_{IN}$		100		$\Omega$	
Differential data input swing	$V_{IN\_PP}$	200		900	mV	
Transmit Disable Voltage	$V_D$	2		$V_{CC}$	V	
Transmit Enable Voltage	$V_{EN}$	$V_{EE}$		$V_{EE}+0.8$	V	

**Electrical – Characteristics – Receiver** **$V_{CC}=3.14V$  to  $3.46V, T_C$** 

Parameter	Symbol	Min	Typ	Max	Unit	Remarks
Differential data output swing	$V_{OUT\_PP}$	300		1000	mV	
LOS Assert	$V_{LOS\_A}$	2		$V_{CC\_HOST}$	V	
LOS De-Assert	$V_{LOS\_D}$	$V_{EE}$		$V_{EE}+0.8$	V	

**Digital Diagnostic Functions**

SFP-25G-LR-C-GEN supports the 2-wire serial communication protocol as defined in SFF-8472. Digital diagnostic information is accessible over the 2-wire interface at the address 0xA2. Digital diagnostics for the transceiver are internally calibrated by default. A micro controller unit inside the transceiver gathers the monitoring information and reports the status of transceiver, such as Transceiver Temperature, Supply Power, TX bias current, TX output power and RX received optical power.

## Block-Diagram-of-Transceiver

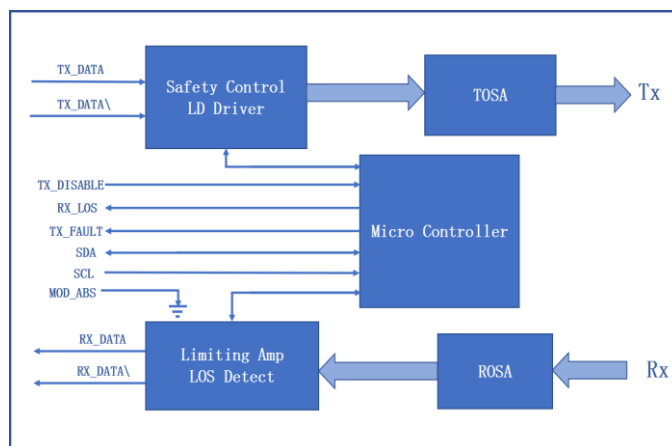

## Functions Description

SFP-25G-LR-C-GEN transceiver consists of a microcontroller, integrated dualclock data recovery function (CDR) laser drive and limiting amplifier, and a Transmitter and a Receiver.

The microcontroller communicates with the host via a 2-wire serial communication interface, providing module control, status reporting and monitoring functions (DOM). This product Compliant with SFF-8472.

The laser driver amplifies the high-speed differential signal recovered from the TX CDR, and drives the laser to generate an optical signal, and maintains the stability of the transmitted optical power through an automatic optical power control feedback loop.

The limiting amplifier amplifies the electrical signal converted by the light receiving component, and outputs the fixed frequency signal to the RX CDR. At the same time, the limiting amplifier detects the amplitude of the electrical signal converted by the light receiving component, and if it is lower than the set threshold, it reports that the received signal is lost, and raise the RX\_LOS pin level on the gold finger. LOS signal is only related to the amplitude of the electrical signal, not to the signal rate and whether the CDR is locked or not.

The transmitter of the transceiver adopts a TO-CAN structure, and is composed of a DFB laser and a monitoring photodiode(MPD). The laser generates a corresponding optical signal according to a bias current and a modulation current provided by the laser driver, and the MPD will continuously monitor the TX power.

The Receiver of the transceiver also uses a TO-CAN structure, including a PIN photodetector(PIN PD) and a trans-impedance amplifier(TIA). When ROSA detects the incident light signal, it will be converted into photo-generated current by the PIN PD. The photo-generated current is converted into an electrical signal through the TIA and input to the limiting amplifier.

The transceiver only supports high data rates 24.33G/25.78G(CPRI options 10/25GbE). At this rate, the transmitter and receiver CDRs will lock, beyond this rate, the CDRs will loss of lock and the link will not work.

We can provide different CDR configurations for different applications, such as 10G/25G dual-rate application, full-rate CDR bypass application and so on. For more details, please contact our sales.

## Dimensions

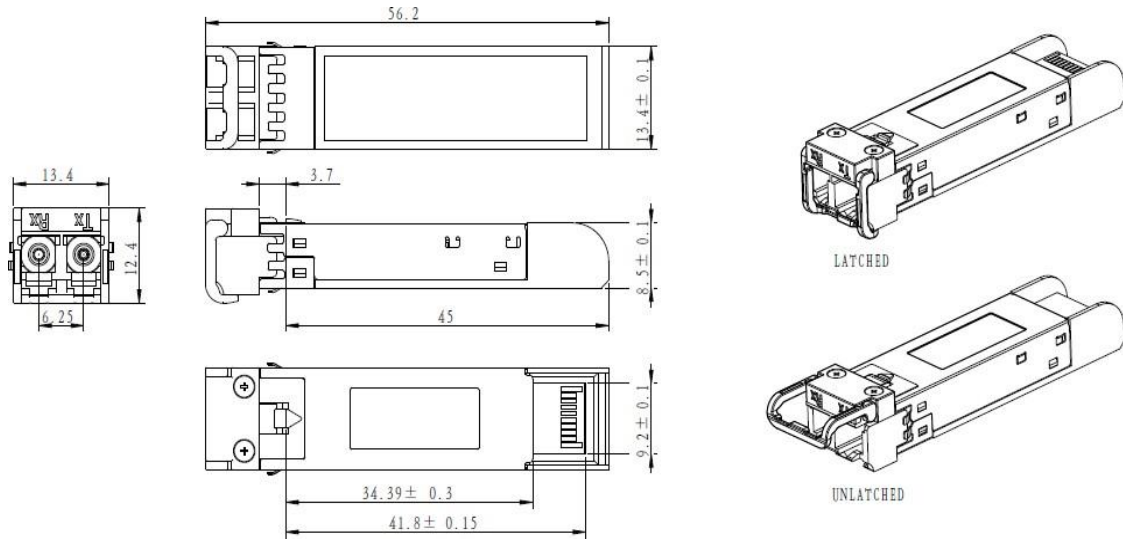

ALL DIMENSIONS ARE  $\pm 0.2$ mm UNLESS OTHERWISE SPECIFIED  
UNIT: mm

## Electrical Pad Layout

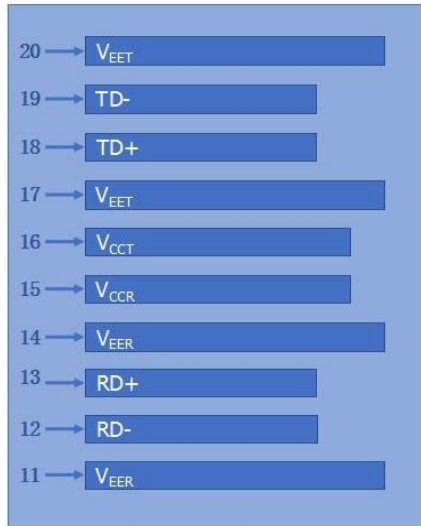

Top of Board

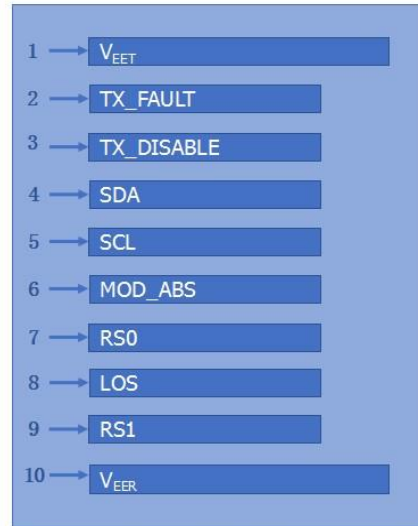
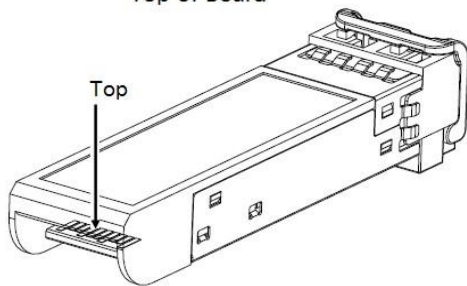

Bottom of Board

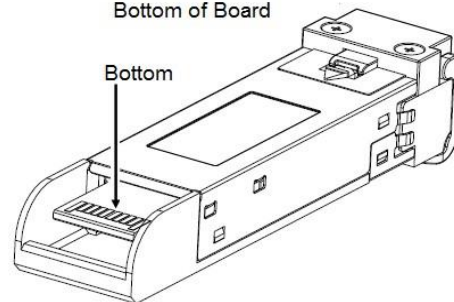

## Pin Assignment

PIN #	Symbol	Description	Remarks
1	V <sub>EET</sub>	Transmitter ground (common with receiver ground)	1
2	TX_FAULT	Transmitter Fault	2
3	TX_DISABLE	Transmitter Disable. Laser output disabled on high or open	3
4	SDA	2-wire Serial Interface Data Line	4
5	SCL	2-wire Serial Interface Clock Line	4
6	MOD_ABS	Module Absent. Grounded within the module	4
7	RS0	No connection required	
8	LOS	Loss of Signal indication. Logic 0 indicates normal operation	5
9	RS1	No connection required	1
10	V <sub>EER</sub>	Receiver ground (common with transmitter ground)	1
11	V <sub>EER</sub>	Receiver ground (common with transmitter ground)	1
12	RD-	Receiver Inverted DATA out. AC coupled	
13	RD+	Receiver Non-inverted DATA out. AC coupled	
14	V <sub>EER</sub>	Receiver ground (common with transmitter ground)	1
15	V <sub>CCR</sub>	Receiver power supply	
16	V <sub>CCT</sub>	Transmitter power supply	
17	V <sub>EET</sub>	Transmitter ground (common with receiver ground)	1
18	TD+	Transmitter Non-Inverted DATA in. AC coupled	
19	TD-	Transmitter Inverted DATA in. AC coupled	
20	V <sub>EET</sub>	Transmitter ground (common with receiver ground)	1

### Notes:

1. Circuit ground is isolated from chassis ground
2. TX\_FAULT is the open collector output and should be pulled up with 4.7k–10k ohm on host board to a voltage between 2V and V<sub>cc</sub>+0.3V
3. Disabled: T<sub>DIS</sub>>2V or open, Enabled: T<sub>DIS</sub><0.8V
4. Should be pulled up with 4.7k - 10k ohm on host board to a voltage between 2V and V<sub>cc</sub> + 0.3V
5. LOS is open collector output and should be pulled up with 4.7k - 10k ohm on host board to a voltage between 2V and V<sub>cc</sub>+0.3V, the logic "0" indicates normal operation, and the logic "1" indicates that the receiver signal is lost.

## References

1. Specification for SFP+ 1X 28Gbps Pluggable Transceiver Solution - SFF-8402.
2. Specification for SFP+ Module and Cage - SFF-8432.
3. Specification for Diagnostic Monitoring Interface for SFP+ - SFF-8472.